



SDM-160/SDM-160P/SDM-160M/SDM-160MP

USER'S MANUAL



DIGITAL MULTIPLEXER

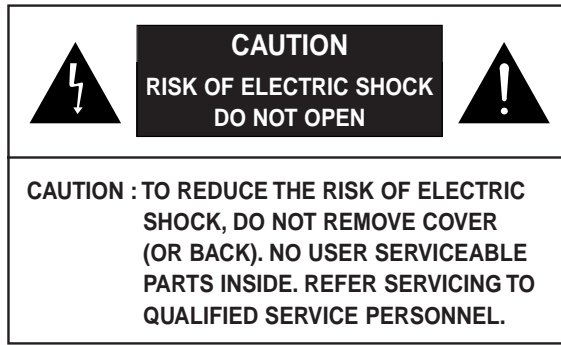

Graphic Symbol Explanation

The lightning flash with arrowhead symbol, within an equilateral triangle, is intended to alert the user to the presence of uninsulated “dangerous voltage” within the product’s enclosure that may be of sufficient magnitude to constitute a risk of electric shock to persons.

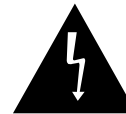

The exclamation point within an equilateral triangle is intended to alert the user to the presence of important operating and maintenance (servicing) instructions in the literature accompanying the appliance.



Warning-To Prevent Fire or Shock Hazard, Do Not Expose This Equipment To Rain or Moisture.

IMPORTANT SAFEGUARDS

1. **Read instructions:** All the safety and operating instructions should be read before the appliance is operated.
2. **Retain instructions:** The safety and operating instructions should be retained for future reference.
3. **Heed warnings:** All warnings on the appliance and in the operating instructions should be adhered to.
4. **Follow instructions:** All operating and use instructions should be followed.
5. **Cleaning:** Unplug this video product from the wall outlet before cleaning. Do not use liquid cleaners or aerosol cleaners. Use a damp cloth for cleaning.
6. **Attachments:** Do not use attachments not recommended by the video product manufacturer as they may cause hazards.
7. **Water and moisture:** Do not use this video product near water - for example, near a bath tub, wash bowl, kitchen sink, or laundry tub, in a wet basement, or near a swimming pool, and the like.
8. **Accessories :** Do not place this video product on an unstable cart, stand, tripod, bracket, or table.

The video product may fall, causing serious injury to a child or adult, and serious damage to the appliance. Use only with a cart, stand, tripod, bracket, or table recommended by the manufacturer, or sold with the video product.

Any mounting of the appliance should follow the manufacturer's instructions and should use a mounting accessory recommended by the manufacturer.



- 8A. An appliance and cart combination should be moved with care. Quick stops, excessive force, and uneven surfaces may cause the appliance and cart combination to overturn.
9. **Ventilation** : Slots and openings in the cabinet are provided for ventilation and to ensure reliable operation of the video product and to protect it from overheating, and these openings must not be blocked or covered. The openings should never be blocked by placing the video product on a bed, sofa, rug, or other similar surface. This video product should never be placed near or over a radiator or heat register. This video product should not be placed in a built-in installation such as a bookcase or rack unless proper ventilation is provided or the manufacturer's instructions have been adhered to.
10. **Power sources** : This video product should be operated only from the type of power source indicated on the marking label. If you are not sure of the type of power supply to your home, consult your appliance dealer or local power company. For video products intended to operate from battery power, or other sources, refer to the operating instructions.
11. **Power-Cord Protection** : Power-supply cords should be routed so that they are not likely to be walked on or pinched by items placed upon or against them, paying particular attention to cords at plugs, convenience receptacles, and the point where they exit from the appliance.
12. **Lightning** : For added protection for this video product during a lightning storm, or when it is left unattended and unused for long periods of time, unplug it from the wall outlet and disconnect the cable system. This will prevent damage to the video product due to lightning and power-line surges.
13. **Overloading** : Do not overload wall outlets and extension cords as this can result in a risk of fire or electric shock.
14. **Object and liquid entry** : Never push objects of any kind into this video product through openings as they may touch dangerous voltage points or short-out parts that could result in a fire or electric shock. Never spill liquid of any kind on the video product.
15. **Servicing** : Do not attempt to service this video product yourself as opening or removing covers may expose you to dangerous voltage or other hazards. Refer all servicing to qualified service personnel.
16. **Damage requiring service** : Unplug this video product from the wall outlet and refer servicing to qualified service personnel under the following conditions.
 - a. When the power-supply cord or plug is damaged.
 - b. If liquid has been spilled, or objects have fallen into the video product.
 - c. If the video product has been exposed to rain or water.
 - d. If the video product does not operate normally by following the operating instructions. Adjust only those controls that are covered by the operating instruction, as an improper adjustment of other controls may result in damage and will often require extensive work by a qualified technician to restore the video product to its normal operation.
 - e. If the video product has been dropped or the cabinet has been damaged.
 - f. When the video product exhibits a distinct change in performance this indicates a need for service.
17. **Replacement parts** : When replacement parts are required, be sure the service technician has used replacement parts specified by the manufacturer or have the same characteristics as the original part. Unauthorized substitutions may result in fire, electric shock or other hazards.
18. **Safety Check** : Upon completion of any service or repairs to this video product, ask the service technician to perform safety checks to determine that the video product is in proper operating condition.

CONTENTS

CHAPTER 1. INTRODUCTION	1-1~1-4
Introduction.....	1-1
Functions and Features	1-1
Name of parts and Function	1-2
Front panel.....	1-2
Rear panel.....	1-4
CHAPTER 2. INSTALLATION	2-1~2-4
Preparing for the Installation	2-1
Precautions when Installing	2-2
Unpacking.....	2-4
CHAPTER 3. CONNECTING TO OTHER DEVICES	3-1~3-6
Connecting to normal VCR and Monitor.....	3-1
Connecting to S-VHS VCR and S-VHS MONITOR.	3-1
Connecting to TIME LAPSE VCR	3-2
Connecting to ALARM sensor.....	3-3
Remote Control by connecting to PC.	3-4
Connecting to RS-232C	3-4
Connecting to RS485.....	3-5
CHAPTER 4. BASIC METHOD TO USE	4-1~ 4-5
Initial operation	4-1
When desiring to see in the live screen/replay screen.....	4-1
When desiring to see in the TRIPLEX screen.....	4-1
When desiring to see in the FULL screen.....	4-2
When desiring to see in the division screen.....	4-2
When desiring to see automatic sequential conversion screen.....	4-3
When desiring to see the stop screen	4-4
When desiring to see in the zoom screen	4-4
When desiring to see in the PIP screen	4-5
When desiring to see in the record screen.....	4-5
When desiring to see output of VCR as it is	4-5

- CHAPTER 5. SETTING OF PROGRAM MENU 5-1~ 5-10**
 - Record setting of each camera5-1
 - Setting of display mode.....5-3
 - Setting of title by channel.....5-5
 - Setting of display mode for current time, year, month and date5-6
 - Setting of alarm5-7
 - Setting of motion5-7
 - System setting.....5-9

- CHAPTER 6. RECORDING 6-1~6-2**
 - Normal record mode6-1
 - TIME LAPSE record mode.6-1
 - Weight value (REC DUTY) record.....6-2
 - ALARM weight value record6-2
 - Reservation record6-2

- CHAPTER 7. OCCURRENCE AND HANDLING OF ALARM,
LOSS, MOTION 7-1~7-2**
 - Alarm occurrence conditions.....7-1
 - Alarm release7-1
 - Screen conversion.....7-1
 - Alarm record.....7-1
 - Alarm signal standard7-1
 - Alarm/Loss list reference.....7-2
 - Operation in video loss.....7-2
 - Operation in motion detection.....7-2

- APPENDIX A SPECIFICATIONS A-1~A-2**
 - SpecificationsA-1
 - Outside drawingA-2

- APPENDIX B CHECKING POINTS IN TROUBLE**
 -B-1

CHAPTER 1.INTRODUCTION

Introduction

This unit can combine up to 16 Camera Images onto one VCR, and both frequent recording and sequential recording can be possible in the unit of Frame and Field, and assigned channel can be played back selectively, and it is Triplex with which Live Mode, Playback Mode, and Live plus Playback Mode can be done in one monitor.

Functions and Features

- System Setup Menu Button allows you to configure the system the way you want.
- Up to 16 asynchronous camera images can be connected.
- Up to 16 camera images can be combined onto one monitor so that multi-screen viewing is made possible.
- Multi-view screen which supports simultaneous viewing of live cameras during playback of recorded scenes.
- 4xzoom is allowed.
- Built-in Video Motion Detection Function.
- Using Spot Output, specific screen can be monitored.
- With Freeze Function, you can view a still picture.
- With Auto Sequence Mode, each channel can be viewed sequentially.
- Date, Time, and Alarm Display Functions can be reset.
- For remote control, RS-232C or RS-485 Cable can be connected to PC.
- This unit can be powered from 100 to 240V AC.
- When Alarm Signal was input, the CHANNEL number, which indicates ALARM, is displayed with warning sound. Besides, if more than two ALARM signals occur simultaneously, you will have Multi Mode with which several channels can be monitored at the same time.
Such ALARM information is recorded in ALARM LIST.
- With the Channel Loss Detection function, if Channel Loss occurs, the CHANNEL number, which indicates LOSS, is displayed. Such CHANNEL LOSS information is recorded in "ALARM/LOSS LIST."

Name of parts and Function

FRONT PANEL

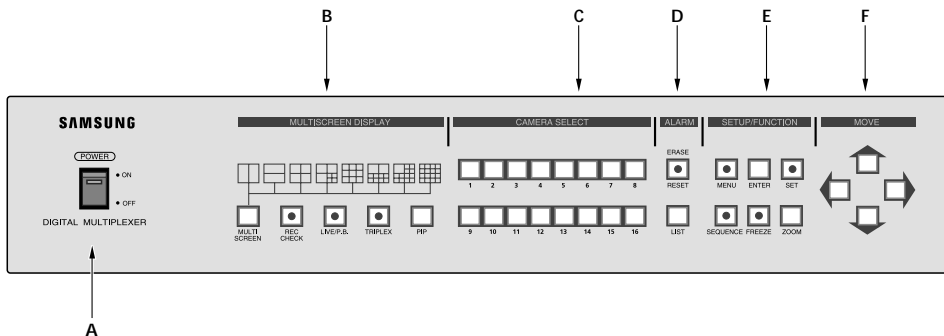

A. POWER SWITCH

Power ON/OFF.

B. MULTI SCREEN DISPLAY

- MULTI SCREEN

You are in the multi-screen mode. Each press of the MULTI SCREEN Button shows the picture displayed.

- REC CHECK

LIVE MODE: VCR output is displayed on the monitor.

P.B MODE: VCR input is displayed on the monitor.

This mode flashes during REC CHECK operation.

- LIVE/P. B.

Button for selecting either LIVE MODE or Playback MODE. LIVE MODE will be flashed.

- TRIPLEX

Button for selecting TRIPLEX MODE. Flashes during TRIPLEX operation.

- PIP

Button for selecting PICTURE-IN-PICTURE.

C. CAMERA SELECT

Button for selecting proper CHANNEL.

D. ALARM

- RESET/ERASE

Button for deactivating ALARM. When ALARM is input, RESET/ERASE Button should illuminate.

When "ALARM/LOSS LIST" is displayed on the screen, pressing this Button will erase page by page.

- LIST

Shows ALARM/LOSS LIST.

E. SETUP/FUNCTION

- MENU

Pressing this Button will make LED lit, and MAIN MENU appears on the screen.

- ENTER

Used when switching from MAIN MENU to SUB MENU.

- SET

This function is used when moving from SUB MENU to MAIN MENU after setting programs on each MENU screen, or is used when setting each channel for multi-screen. When setting channels for multi-screen, the channel number flashes.

- SEQUENCE

When pressing this Button, each Channel will automatically be switched to the next channel sequentially with some time intervals, and LED should illuminate. Pressing again will stop illuminating, and stops sequencing.

- FREEZE

When pressing this Button, selected screen becomes still, and LED should illuminate.

- ZOOM

When pressing this Button, the screen should enlarge. Pressing once enlarges twice, and another pressing enlarges 4 times, and pressing once again will bring the screen back to normal.

F. MOVE (↑ , ↓ , ← , →)

This function is used when setting Program Menu, Channel of Multi-screen, and Zoom Mode, and also when moving Cursor.

PANEL TRASERO

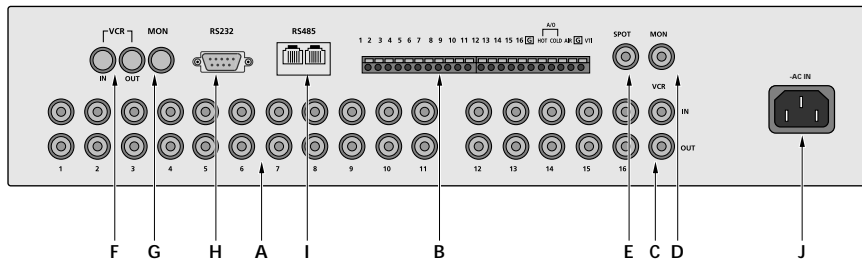

A. CAMERA INPUT / LOOP THROUGH OUT

- Up to 16 camera signals can be input. When transmitting camera signals to external devices, OUT terminal can be used.

B. ALARM IN / ALARM OUT / VTI TERMINAL

- VTI: TRIGGER Output Connection terminal of VCR
- ALARM IN: Up to 16 ALARM Sensors can be connected. "G" indicates grounding terminal connected to ALARM Input, and should be connected to grounding terminal of sensors.
- ALARM OUT (HOT/COLD): When ALARM is activated, ACTIVE MAKE Signal is generated.
- ALARM RESET : Connected to RESET terminal of VCR, and when ALARM is deactivated, PULSE is generated.

C. VCR IN/OUT (BNC)

Indicates terminal for connecting to VCR Input/Output.

D. MONITOR OUT (BNC)

Indicates terminal for connecting to Monitor's video Input terminal.

E. SPOT OUT (BNC)

Indicates terminal for connecting to Monitor's video Input terminal.

F. VCR IN/OUT (4PIN MINI DIN)

Indicates terminal for connecting to VCR's S-VHS Input/Output terminal.

* SDM-160M/SDM-160MP: Not used.

G. MONITOR OUT (4PIN MINI DIN)

Indicates terminal for connecting to Monitor's video S-VHS Input terminal.

* SDM-160M/SDM-160MP: Not used.

H. RS-232C

With RS-232C cable, Remote Control can be done.

I. RS-485

With RS-485 cable, Remote Control can be done.

J. ~AC IN

Connects to Power Cord.

CHAPTER 2. INSTALLATION

Preparing for the Installation

The following information is prepared for safe installation of the unit.

This unit can be placed on a flat table or installed in the rack. It should not be used vertically or skew, but horizontally. The location of the unit and the composition of wiring are very important in properly operating the system. When equipment is placed too close or if ventilation is not properly done, system may not work properly, and maintenance of the system may be difficult. In order to prevent system failure and to reduce system shut-down by outside environmental factors, air circulation in the system operating room, and the cover of the unit must be fixed. Do not open the cover voluntarily because high voltage within the unit may cause electric shock.

PHYSICAL & ENVIRONMENTAL

- Operating Temperature : 0 °C to 40 °C
- Maintenance Temperature : -20 °C to 60 °C
- Operating Humidity : 20% to 85% (RH)
- Maintenance Humidity : 20% to 95% (RH)
- Power Supply : 100 ~ 240 VAC
- Power Consumption : less than 14W
- Frequency : 50 / 60 Hz

CAUTIONS

When system is operated, input voltage range must be within 10% of nominal voltage, and power consent should be grounded. Heating devices such as hair dryer, iron, refrigerator should not be used together.

For safe power supply, AVR (Automatic Voltage Regulator) is recommended.

The connector linked to this equipment can affect EMI, so it is recommended to coil the CORE-FERRITE for use.

Precautions when Installing

Precautions when Installing

- Be sure to turn the unit off before installing.

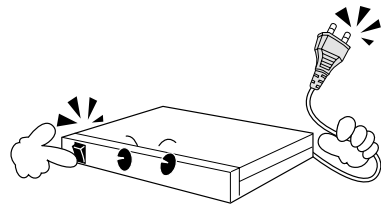

- Avoid shock or vibration since they may cause unit malfunction.

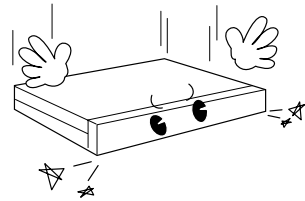

- Keep away from magnets, radio or TV to avoid magnetic damage.

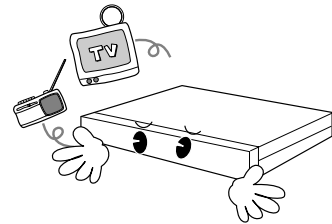

- During or after installing the unit, be sure to maintain the area around the unit clean.

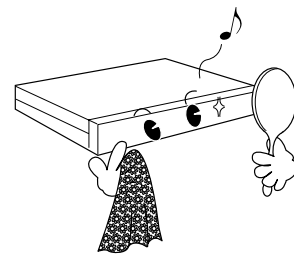

- Place the unit on a flat surface and maintain temperature properly. Allow 15 cm of clearance between the rear panel and the wall.

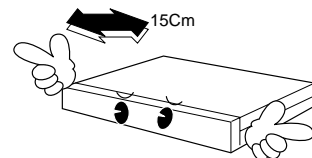

- Be careful not to drop any conductive materials into the hole for ventilation

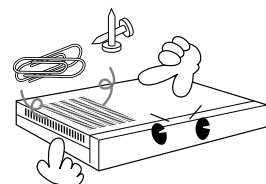

- When replacing built-in fuse, be sure to turn the power off, and unplug the unit.

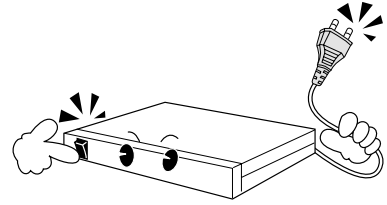

- Avoid locating the unit where direct sunlight will fall, and maintain it cool. Keep tools and equipment away from people so that they would not be hurt.

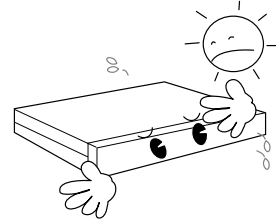

- Power Outlet should be grounded 2P(or 3P)Type.

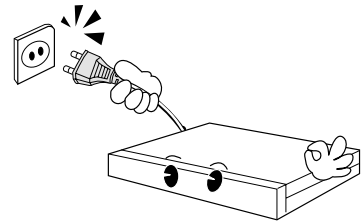

- If ignoring smoke or smell while using the unit, fire or electric shock may occur. In this case, turn the power switch off immediately, and consult professionals in the closest service center.

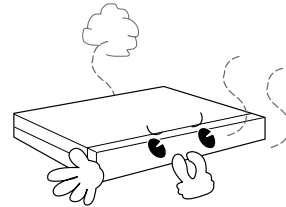

- Be sure to check dangers, which may occur due to damped floor, ungrounded power extension cable, worn power cord or lack of safety grounding.

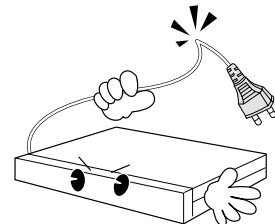

CAUTIONS

When cleaning this unit, be sure to wipe with a dried cloth. If the unit is heavily contaminated, wipe it with a soft cloth dampened with a mild detergent solution, then wipe dry with a soft clean cloth. Do not use chemicals such as alcohol, benzene, or thinner because a chemical reaction could result permanent damaging of the cabinet surface.

UNPACKING

Place shipping container on a flat surface, cut straps or tape, open top. Then, review the content; the following items should be included:

- Main Unit
- User Manual (this document)
- One (1) Power Unit
- Two Rack Mount Adaptors

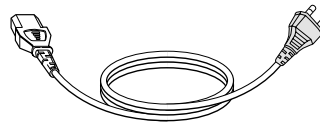
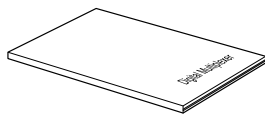
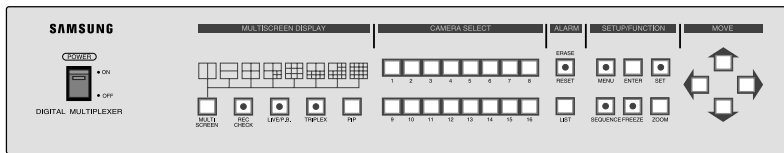

CHAPTER 3. Connecting to Other Devices

This unit can be connected to other devices such as monitor, camera, VCR, and PC. This chapter describes how to connect the unit to other devices.

CAUTIONS

Be sure that voltages higher than 2 VDC should not be input to the input terminal of Camera and Video.

1. Connecting to normal VCR and Monitor

When connecting to a normal VCR, Select 'NOR' in "REC TYPE" of "1. REC OUT SET" in SETUP MENU.

1. Connect a BNC cable to the VCR IN terminal on the Unit Rear Panel and to the OUT terminal of the VCR.
2. Connect a BNC cable to the VCR OUT terminal on the Unit Rear Panel and to the IN terminal of the VCR.
3. Connect a BNC cable to the MON OUT terminal on the Unit Rear Panel and to the IN terminal of the Monitor.

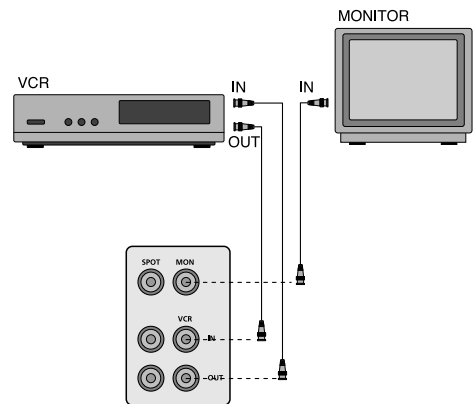

2. Connecting to S-VHS VCR and S-VHS MONITOR

When playing back TAPE by connecting to S-VHS, select "Y/C" in "PB IN" Mode, once you in "2.MON OUT SET" Mode in SETUP Menu.

1. Connect a S-JACK cable to the VCR IN 4-pin terminal on the Unit's Rear Panel and to the OUT terminal on the VCR.
2. Connect a S-JACK cable to the VCR OUT 4-pin terminal on the Unit's Rear Panel and to the IN terminal on the VCR.
3. Connect a S-JACK cable to the MON OUT 4-pin terminal on the Unit's Rear Panel and to the IN terminal on the Monitor.

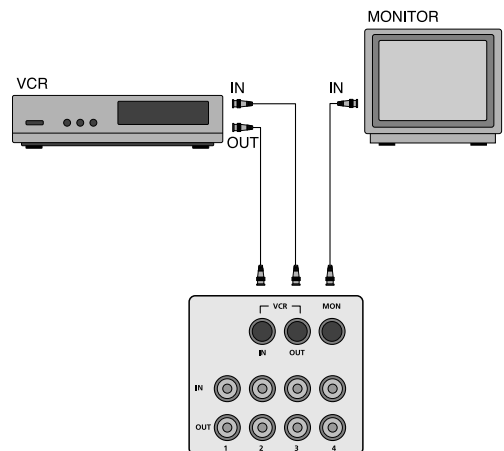

* SDM-160M/SDM-160MP:Not used.

3. Connecting to TIME LAPSE VCR

When connecting the unit to the TIME LAPSE VCR, set "TLV" in "REC TYPE" after selecting "1.REC OUT SET" of SETUP MENU.

1. Connect a S-JACK cable to the VTI terminal on the Unit's Rear Panel and to the REC TRIG OUT terminal on the VCR.
2. Connect a S-JACK cable to the 'G' terminal on the Unit's Rear Panel and to the 'G' terminal on the VCR.
3. Connect a cable to the VCR IN terminal on the Unit's Rear Panel and to the VCR OUT terminal on the VCR. Likewise, connect a cable to the VCR IN terminal on the Unit's Rear Panel and to the VCR OUT terminal on the VCR.

CAUTIONS

Depending on the kinds of TIME LAPSE VCR, the name of REC TRIGGER OUT terminal may be different, so be sure to connect after checking its name.

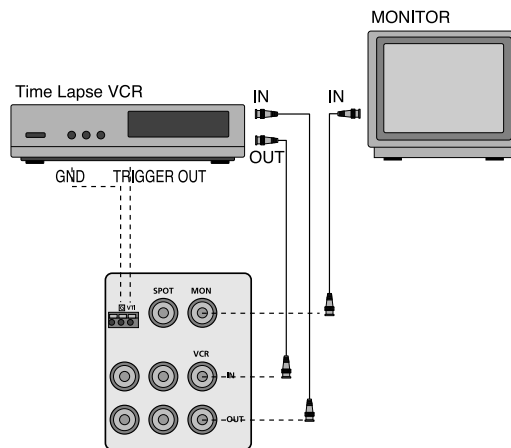

4. Connecting to ALARM SENSOR

1. Connect the ALARM terminal on the Unit's Rear Panel to the SENSOR CORRESPONDING TO camera number.
2. Connect grounding wires.
3. Connect the HOT terminal on the Unit's Rear Panel to the ALARM IN terminal on the VCR.
4. Connect the COLD terminal on the Unit's Rear Panel to the COM terminal on the VCR.
5. Connect the A/R terminal on the Unit's Rear Panel to the RESET terminal on the VCR.

CAUTIONS

Depending on the kinds of TIME LAPSE VCR, the name of REC TRIGGER OUT terminal may be different, so be sure to connect after checking its name.

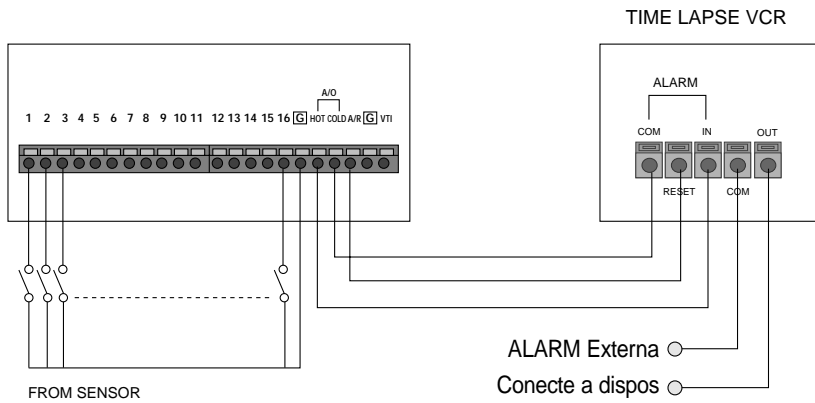

5. Remote Control by connecting to PC

A. Connecting to RS-232C

The unit can be remote-controlled by connecting to PC in which terminal emulation program is built. At this time, RS-232C Cable is used for connection. When connecting to the PC by RS-232C, some keys on the PC keyboard can be used as Function Buttons on the Unit's Front Panel. RS-232C Terminal(D-SUB 9PIN)

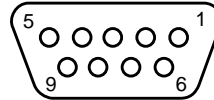

RS-232C 9PIN(Connector Allocation)

PIN NUMBER	PIN SPECIFICATIONS
2	TXD(TRANSMITTED DATA)
3	RXD(RECEIVED DATA)
5	SG(SIGNAL GROUND)
1, 4, 6~9	NO CONNECTION

ASCII	Function	ASCII	Function
1	CH1	T	TRIPLEX
2	CH2	P	PIP
3	CH3	R	RESET
4	CH4	L	LIST
5	CH5	M	MENU
6	CH6	A(AUTO)	SEQUENCE
7	CH7	E	ENTER
8	CH8	F	FREEZE
9	CH9	S	SET
a(HEX)	CH10	Z	ZOOM
b(HEX)	CH11	h	(MOVE ↑)
c(HEX)	CH12	i	(MOVE ↓)
d(HEX)	CH13	j	(MOVE ←)
e(HEX)	CH14	k	(MOVE →)
f(HEX)	CH15	l	LEFT_UP
g(SEMI-HEX)	CH16	m	LEFT_DOWN
W(WINDOW)	MULTI SCREEN	n	RIGHT_UP
C	REC CHECK/PB THROUGH	o	RIGHT_DOWN
V	LIVE/PB		

- Transmission speed : Select from 4800,9600, 19200, 38400 bps
- data bit : 8 bits
- parity : none
- stop bit : 1 bit

B. Connecting to RS485

RS485

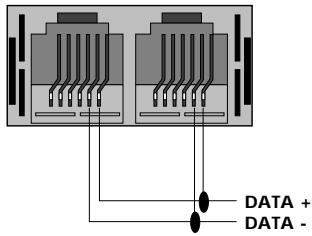

Connecting RS485 and DATA PROTOCOL

1. Communication Method

Data Transmission Type : RS485

Protocol : 8 bit data, 1 Stop bit, None Parity

Transmission Speed: 4800, 9600, 19200, 38400 bps

2.Data Format

9Byte Fixed

byte

Data Byte	Type	Description	Remarks
Byte 1	Start Code	A0H	Beginning of Data Packet
Byte 2	Sender Addr	Transmitting address	Address of data transmitting side
Byte 3	Target Addr	Receiving address	Triplexer RS-485 addr. (0~255)
Byte 4		Triplex Control Command	
Byte 5	Command	KEY DATA	0x00-0x28
Byte 6		0xff	
Byte 7		0xff	
Byte 8		0xff	
Byte 9	Check Sum	Lower value of (0xffff - (Summing from Byte2 to Byte8))	

No.	Item	Byte4	Byte5	Byte5	Byte6	Byte7
1	CH1	0x05	0x01	0xff	0xff	0xff
2	CH2	0x05	0x02	0xff	0xff	0xff
3	CH3	0x05	0x03	0xff	0xff	0xff
4	CH4	0x05	0x04	0xff	0xff	0xff
5	CH5	0x05	0x05	0xff	0xff	0xff
6	CH6	0x05	0x06	0xff	0xff	0xff
7	CH7	0x05	0x07	0xff	0xff	0xff
8	CH8	0x05	0x08	0xff	0xff	0xff
9	CH9	0x05	0x09	0xff	0xff	0xff
10	CH10	0x05	0x0a	0xff	0xff	0xff
11	CH11	0x05	0x0b	0xff	0xff	0xff
12	CH12	0x05	0x0c	0xff	0xff	0xff
13	CH13	0x05	0x0d	0xff	0xff	0xff
14	CH14	0x05	0x0e	0xff	0xff	0xff
15	CH15	0x05	0x0f	0xff	0xff	0xff
16	CH16	0x05	0x10	0xff	0xff	0xff
15	MULTI	0x05	0x11	0xff	0xff	0xff
16	REC_CHECK	0x05	0x12	0xff	0xff	0xff
17	LIVE/PB	0x05	0x13	0xff	0xff	0xff
18	TRIPLEX	0x05	0x14	0xff	0xff	0xff
19	PIP	0x05	0x15	0xff	0xff	0xff
20	RESET	0x05	0x16	0xff	0xff	0xff
21	LIST	0x05	0x17	0xff	0xff	0xff
22	MENU	0x05	0x18	0xff	0xff	0xff
23	SEQUENCE	0x05	0x19	0xff	0xff	0xff
24	ENTER	0x05	0x1a	0xff	0xff	0xff
25	FREEZE	0x05	0x1b	0xff	0xff	0xff
26	SET	0x05	0x1c	0xff	0xff	0xff
27	ZOOM	0x05	0x1d	0xff	0xff	0xff
28	LEFT	0x05	0x1e	0xff	0xff	0xff
29	RIGHT	0x05	0x1f	0xff	0xff	0xff
30	UP	0x05	0x20	0xff	0xff	0xff
31	DOWN	0x05	0x21	0xff	0xff	0xff
32	LEFT_UP	0x05	0x22	0xff	0xff	0xff
33	LEFT_DN	0x05	0x23	0xff	0xff	0xff
34	RIGHT_UP	0x05	0x24	0xff	0xff	0xff
35	RIGHT_DN	0x05	0x25	0xff	0xff	0xff

Chapter 4. Basic Method to use

Initial operation

1. Turn on power switch.

A 4-division screen appears on the monitor if firstly operating after purchase. In this case, the channel without inputting appears in the blue background on the screen and a video loss occurs.

(The current operation status is memorized when the power turns off after completing the initial setting and thus the unit operates in the operation status when the power turns off if turning power on.)

2. Setup a recording channel.

Set the channel without inputting to "off" in the "DUTY SET" of "1.REC OUT SET" on the program menu.

3. Change it to a desiring indication mode.

- Indication of FULL screen: The selected channel is indicated on monitor in the form of FULL channel.
- Indication of division screen: The division screen is indicated on monitor if pressing the multi-screen button. Resetting channel is available for the division screen if user wants.
- Indication of automatic sequential conversion: The full screen is automatically converted if pressing the sequence button.
- Indication of stop screen: A desired channel can be seen in a form of stop screen using the freezing button and camera selection button.
- Indication of live/P.B: The current camera signal may be monitored or the recorded screen may be reproduced for a view using the live/P.B button.
- Indication of TRIPLEX screen: The current camera signal and the recorded screen may be seen on the same monitor using the TRIPLEX button.
- Indication of PIP screen: The PIP (picture in picture) screen may be seen using the PIP button.
- Indication of expansion screen: The full screen may be expanded up to 4 times for view using the zoom and move button.
- Indication of record check screen: The recorded output screen or the output screen of VCR may be seen using the REC CHECK button.

When desiring to see in the live screen/replay screen

The "live/P.B" select button determines the live screen/replay screen mode.

The LED turns on in the live mode and it turns off in the tape replay mode.

If pressing this button, the indication mode is changed to the replay mode for the live mode and to the live mode for the replay mode.

➤ The "LIVE/P.B" button does not operate in the following cases:

- During zoom operation
- In setting of program mode
- In displaying ALARM/LOSS LIST on screen

When desiring to see in the TRIPLEX screen

The "TRIPLEX" button sets the TRIPLEX screen mode. In this case the LED turns on and the previous TRIPLEX division mode is set.

➤ The "TRIPLEX" button does not operate in the following cases:

- During zoom operation
- In setting of program mode
- In displaying ALARM/LOSS LIST on screen

When desiring to see in the FULL screen

The FULL screen may be seen in the live and tape replay mode, available for 16 channels from No.1 through No.16.

- Method to use.
 - Press the camera select button of the desired channel.
- The camera select button does not operate in the following cases:
 - In setting of program mode
 - In displaying ALARM/LOSS LIST on screen
 - In setting FREEZE in the division screen
 - In resetting of channel in the division screen

When desiring to see in the division screen

The division screen may be seen in the live replay mode and triplex mode and the division mode of 2, 4, 7, 9, 10, 13, 16 exists as a screen select mode.

The only division mode of 2, 4, 9, 16 is available in the triplex mode.

- Method to use
 - Press the "multi screen" button until reaching the desired division indication mode.
- Channel resetting method
 - 1) Press the "SET" button. In this case the SET LED turns on and the BORDER LINE on the left upper of screen blinks.
 - 2) Move the section whose border blinks to a desired position using the move button.
 - 3) Press the "CAMERA SELECT" button equivalent to the desired channel at the position.
 - 4) Repeat operation in 2), 3) until setting is completed.
 - 5) Press the "SET" button after completing setting.
- The previously indicated division indication mode is returned if selecting the division screen using the "MULTI SCREEN" button on the full screen.
- "MULTI SCREEN" button does not operate in the following cases:
 - In setting division screen
 - In setting of program mode
 - In displaying ALARM LIST on screen
 - During zoom operation

When desiring to see automatic sequential conversion screen

The automatic sequential conversion mode operates in the LIVE screen status and consists of the following 2 cases:

The FULL screen is converted if pressing the "SEQUENCE" button in the FULL screen status. The screen on the bottom right side is converted if pressing the "SEQUENCE" button in the 4, 9-division screen status. The LED of the "SEQUENCE" button turns on for both cases.

The conversion time in the automatic sequential conversion mode is set in the "SEQUENCE.." of the "2. MON OUT SET" in case of the PRPROGRAM mode for the FULL screen and the time to set up is 00sec ~ 30sec. The screen set to 00sec is skipped. The screen on the right bottom is switched in the interval of a second for the 4, 9-division screen.

- Method to release
 - Press the "SEQUENCE" button once again. In this case the LED turns off. And then it stops on the screen currently seen.
- The "SEQUENCE" button does not operate in the following cases:
 - In replay mode or TRIPLEX mode
 - In the division screen mode other than 4, 9-division screen
 - In setting of program mode
 - In displaying ALARM LIST on screen
 - During ZOOM operation
 - During ALARM operation

When desiring to see the stop screen

The monitor screen (full screen and division) may be seen with a temporary stop. A desired screen may be temporarily stopped selectively in the division screen indication mode.

1. FREEZE setting of FULL screen

The LED turns on and monitor image stops and "FREEZE" character is indicated on the screen if pressing the "FREEZE" button in the FULL screen mode. The LED turns off and the stop mode is released if pressing the "FREEZE" button once again.

2. FREEZE setting of division screen

The LED blinks if pressing the "FREEZE" button. The selected screen stops if selecting a channel to freeze, and "F" character is displayed. The selected channel is released if pressing the relevant channel again and stop of all channels if pressing the "FREEZE" button.

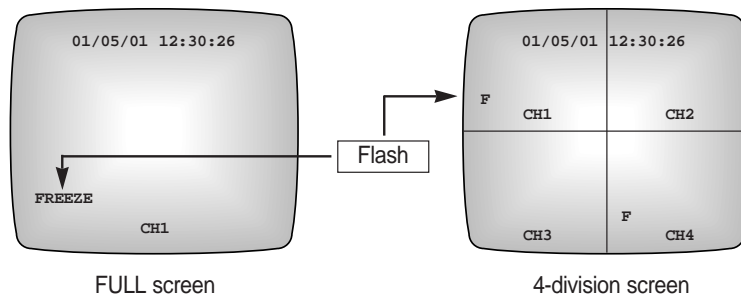

- The "FREEZE" button does not operate in the following cases:
 - In setting division screen mode
 - In setting of program mode
 - In displaying ALARM/LOSS LIST on screen

When desiring to see in the zoom screen

The zoom screen operates if pressing "ZOOM" button in the FULL mode. The mode is changed in the following order whenever pressing this button.



Select the area to expand using the "MOVE" (↑, ↓, ←, →) button.

Moving to the diagonal direction is allowed using the double button (right upper, left below, right upper, right below).

- The "ZOOM" button does not operate in the following cases:
 - In division screen mode
 - In setting division screen
 - In setting of program mode
 - In displaying ALARM LIST on screen

When desiring to see in the PIP screen

The PIP (picture in picture) screen may be seen using the "PIP" button on the FULL screen in the LIVE mode. The size of the PIP sub-screen is set in the "PIP SIZE" of the "2. MON OUT SET" on the program menu. The sub-screen is automatically and sequentially converted if pressing the "SEQUENCE" button.

➤ Method to use

1. Press the "PIP" button.
2. Press the "SET". In this case the LED of the "SET" button blinks and the border line blinks. Then, set the sub-screen of the PIP screen to a desired channel.
3. Press the "SET" button if completing the channel setting. In this case the LED of the "SET" button turns off.
4. Fix the position of the sub-screen using the "MOVE" button. The position of the sub-screen may be selected in 4 cases of right upper, left below, right upper, right below.

➤ The "PIP" button does not operate in the following cases:

- In replay mode or TRIPLEX mode
- In division screen
- In automatic sequential conversion mode
- In zoom operation
- In setting program mode
- In displaying ALARM/LOSS LIST on screen

When desiring to see in the record screen

You can see the record output screen in the live mode using the "REC CHECK".

When desiring to see output of VCR as it is

You can see the output screen of VCR using the "REC CHECK" button in the replay mode. This mode is useful when adjusting MENU of VCR.

➤ The "REC CHECK" button does not operate in the following cases:

- In zoom operation
- In setting program mode
- In displaying ALARM/LOSS LIST on screen

Chapter 5. Setting of Program Menu

<MAIN MENU>

The following main menu is displayed on the monitor screen if pressing "MENU" button, the "MENU" LED turns on. The LED turns off if pressing the button and it returns to the previous status.

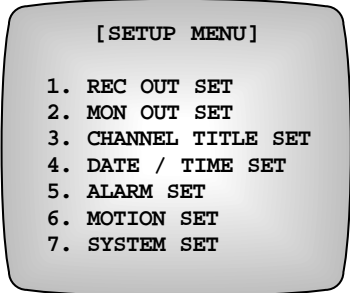

< SUB MENU>

- Select item 1~7 of the main menu using the "MOVE" button (↑ , ↓).
- Press the "ENTER" button to move to the sub-menu.

1. Record setting of each camera

You can set record mode and record duty, ON/OFF, reservation of each channel. The following screen is displayed on screen if pressing the "ENTER" button after placing the blinking indication on the "1. REC OUT SET" by pressing the "MOVE" button from the main menu.

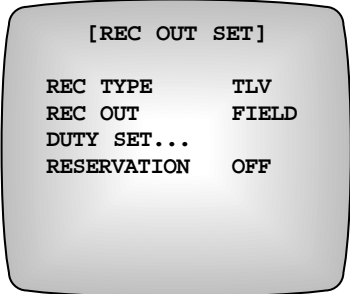

- The blinking indication moves if pressing " ↑ ", " ↓ " button.
- The setting value is changed if pressing " ← ", " → " button.
- The changed setting value is stored if pressing the "SET" button. You can return to the main menu.

REC TYPE : NOR ↔ TLV

- NOR : Used when connecting general VCR. Output is done in Field or Frame.
- TLV : Used when recording in the TLV mode by connecting the time lapse VCR.

- Output in the normal mode if no trigger signal exists though the setting is done in the TLV mode.

REC OUT : FIELD ↔ FRAME : Effective menu if "REC TYPE" is "NOR".

- FIELD : Output in 1/60 second (NTSC), 1/50 second (PAL)
- FRAME : Output in 1/30 second (NTSC), 1/25 second (PAL)

- Reservation : ON ↔ OFF

- The following screen is displayed if pressing the "ENTER" button with the blinking position placed at the "DUTY SET".

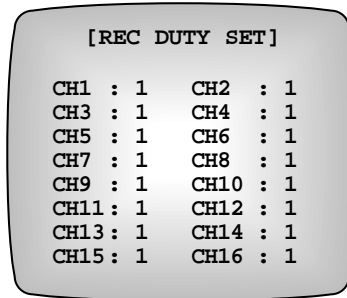

- The blinking indication moves if pressing "↑", "↓" button.
- The setting value is changed if pressing "←", "→" button: OFF, 1~5.
- The relevant channel is not recorded if the setting value is "OFF".
- The changed setting value is stored if pressing the "SET" button. You can return to the main menu.

- The following screen is displayed if pressing the "ENTER" button where the blinking position is "ON..." at the "RESERVATION".

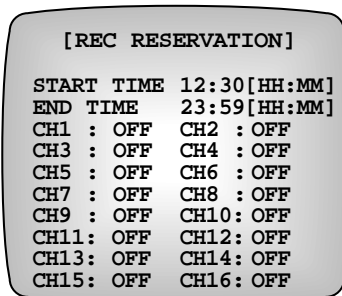

- Useful menu when desiring to record only specific channels at a specific time.
- Record the channels set from the start time to the end time.
- The blinking indication moves if pressing "↑", "↓" button.
- The setting value is changed if pressing "←", "→" button.
 Start time, end time HH : 00 ~ 23
 Start time, end time MM : 00 ~ 59
 CH1 ~ CH16 : OFF ↔ 1 ↔ 2 ↔ 3 ↔ 4 ↔ 5 ↔ OFF
- Channels set to "OFF" does not perform when carrying out reservation record.
- The changed setting value is stored if pressing the "SET" button. You can return to the "REC OUT SET" menu.

2. Setting of display mode

You can set LIVE/PB display type, PIP size, sequence, and border color, PB IN, etc..

The following screen is displayed if pressing the "ENTER" button with the blinking position placed at the "2. MON OUT SET" by pressing "MOVE" button on the main menu.

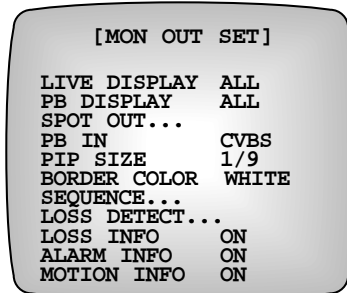

- The blinking indication moves if pressing "↑", "↓" button.
- The setting value is changed if pressing "←", "→" button.

LIVE DISPLAY: ALL ↔ TITLE ↔ DATE/TIME ↔ NONE ↔ ALL

PB DISPLAY : ALL ↔ TITLE ↔ DATE/TIME ↔ NONE ↔ ALL

- ALL: Both date/time and title are displayed.
- TITLE: Only channel title is displayed.
- DATE/TIME : Only date/time is displayed.
- NONE: Both date/time and title are not displayed.

PB IN: CVBS ↔ Y/C

- Set the replay (P, B mode) input.
- Y/C: Input of SUPER VHS
- CBVS: COMPOSITE BNC input
- SDM-160M/SDM-160MP: Not used.

PIP SIZE: 1/9 ↔ 1/16

- Set the size of the sub-screen in the PIP mode.

BORDER COLOR: WHITE ↔ GRAY

- Set color of the division line of the division screen or the PIP screen.
- SDM-160M/SDM-160MP: Not used.

LOSS INFO: ON ↔ OFF

- Set in order to advise LOSS information to the screen.

ALARM INFO: ON ↔ OFF

- Set in order to advise ALARM information to the screen.

MOTION INFO: ON ↔ OFF

- Set in order to advise MOTION information to the screen.

- The following is displayed if pressing the "ENTER" button with the blinking position placed at the "SPOT OUT...":

[SPOT OUT]			
CH1	: 02	CH2	: 00
CH3	: 00	CH4	: 00
CH5	: 00	CH6	: 00
CH7	: 00	CH8	: 00
CH9	: 00	CH10	: 00
CH11	: 00	CH12	: 00
CH13	: 00	CH14	: 00
CH15	: 00	CH16	: 00
ALARM S/W TIME : 02			

- You can set the sequence time of SPOT output.
- The blinking indication moves if pressing "↑", "↓" button.
- The setting value is changed if pressing "←", "→" button.
 CH1~CH16 : 0 to 30 seconds.
 Alarm S/W TIME : 01 to 30 seconds.
- The changed setting value is stored if pressing the "SET" button and you can return to the "MON OUT SET" menu.
- * The channel of LOSS or "0" of sequence time will be skipped in the SPOT output sequence.
- * SPOT OUTPUT on alarm
 When the alarm is activated, only the alarmed channel will be output.
 On single alarm : output only the alarmed channel.
 On multiple alarms : output alarmed channels in turn at intervals of set ALARM S/W TIME.
 (Even the sequence time of the alarmed channel is set as "0" then will be SPOT output.)

- The following is displayed if pressing the "ENTENR" button with the blinking position placed at "SEQUENCE....":

[SEQUENCE]			
CH1	: 02	CH2	: 02
CH3	: 02	CH4	: 02
CH5	: 02	CH6	: 02
CH7	: 02	CH8	: 02
CH9	: 02	CH10	: 02
CH11	: 02	CH12	: 02
CH13	: 02	CH14	: 02
CH15	: 02	CH16	: 02

- Set the indication time (second) of each channel in the automatic conversion mode.
- The blinking indication moves if pressing "↑", "↓" button.
- The setting value is changed if pressing "←", "→" button.
 CH1 ~ CH16 : 0 ~ 30
 "0" is skipped irrespective of existence of channel loss in the automatic conversion mode.
- The changed setting value is stored if pressing the "SET" button and you can return to the "MON OUT SET" menu.

- The following screen is displayed if pressing the "ENTER" button with the blinking position placed at the "LOSS DETECT....":

```

[LOSS DETECT]
CH1 : ON   CH2 : ON
CH3 : ON   CH4 : ON
CH5 : ON   CH6 : ON
CH7 : ON   CH8 : ON
CH9 : ON   CH10: ON
CH11: ON   CH12: ON
CH13: ON   CH14: ON
CH15: ON   CH16: ON
  
```

- Set whether LOSS DETECT by channel will be done.
- The blinking indication moves if pressing "↑", "↓" button.
- The setting value is changed if pressing "←", "→" button. : ON ↔ OFF
- The changed setting value is stored if pressing the "SET" button and you can return to the "MON OUT SET" menu.

3.Setting of title by channel

- You can set of each channel.
- The following screen is displayed if pressing the "ENTER" button with the blinking indication placed the "3. CHANNEL TITLE SET" by pressing the "MOVE" button on the main menu screen:

```

[CHANNEL TITLE SET]
CH1:--- CH1---- CH2:--- CH2----
CH3:--- CH3---- CH4:--- CH4----
CH5:--- CH5---- CH6:--- CH6----
CH7:--- CH7---- CH8:--- CH8----
CH9:--- CH9---- CH10:---CH10---
CH11:---CH11--- CH12:---CH12---
CH13:---CH13--- CH14:---CH14---
CH15:---CH15--- CH16:---CH16---
  
```

- The blinking character moves if pressing "↑", "↓" button.
- The background screen is changed to the relevant channel and the following screen is displayed if pressing the "ENTER" button at a position desired to set title:

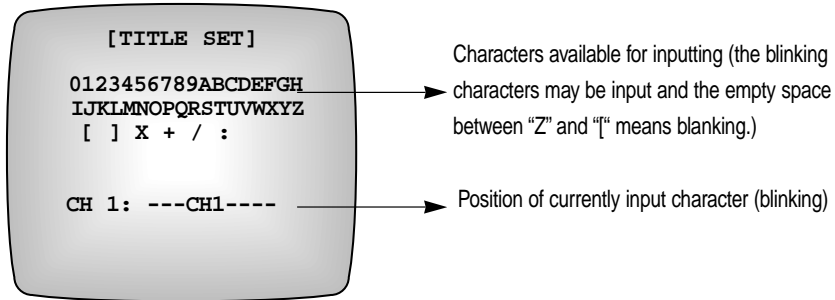

- The position of currently input characters is blinking and moves if pressing “↑”, “↓” button.
- Select character pressing the “←”, “→” button.
- The changed setting value is stored if pressing the “SET” button and you can return to the “CHANNEL TITLE SET” menu.
- Available up to 10 characters.
- * Do not display with the set title for the case of more than 7 – division screen but display by “CH1” ~ “CH16”.
- * A title in the replay mode is “PB1” ~ “PB16” and shall not be set.

4. Setting of display mode for current time, year, month and date

Set the current date and time and the display mode of year, month and date.

The following screen is displayed if pressing the “ENTER” button with the blinking indication placed at the “4.DATE/TIME SET” by pressing the “MOVE” button on the main menu screen:

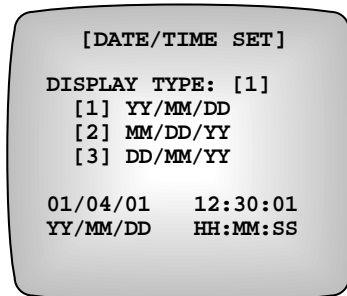

- The blinking character moves if pressing “↑”, “↓” button.
- The setting value is changed if pressing “←”, “→” button.
 - DISPLAY TYPE : 1 ↔ 2 ↔ 3 ↔ 1
 - Year (YY): 00 (2000) ~ 99 (2099)
 - Month (MM): 01 ~ 12
 - Date (DD): 00 ~ 31
 - Time (HH): 00 ~ 23
 - Minute (MM): 00 ~ 59
 - Second (SS): 00 ~ 59
- The changed setting value is stored if pressing the “SET” button and you can return to the main menu.

5. Setting of alarm

Set operation when alarm occurs.

The following screen is displayed if pressing the "ENTER" button with the blinking indication placed at the "5.ALARM SET" by pressing the "MOVE" button on the main menu screen:

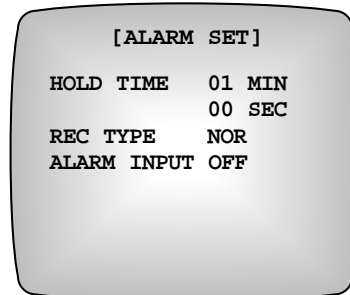

- The blinking character moves if pressing "↑", "↓" button.
- The setting value is changed if pressing "←", "→" button.

HOLD TIME : 00 ~ 30 (MIN)
00 ~ 59 (SEC)

- * The 00 MIN 00 SEC means a manual mode (perform operation for the time the alarm input enters into).

REC TYPE: NOR ↔ TL V

- Set a record mode when alarm occurs.
- ALARM INPUT: OFF ↔ N.O ↔ N.C ↔ OFF
- Set according to the output of alarm sensor connected to the alarm input terminal on the rear side of this unit.
 - OFF: When no alarm input exists.
 - N.O: When alarm input is ACTIVE LOW.
 - N.C: When alarm input is ACTIVE HIGH.

- The changed setting value is stored if pressing the "SET" button and you can return to the main menu.

6. Setting of motion

Set motion detection and operation.

The following screen is displayed if pressing the "ENTER" button with the blinking indication placed at the "6.MOTION SET" by pressing the "MOVE" button on the main menu screen:

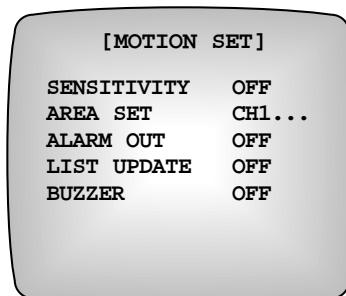

- The blinking character moves if pressing “↑”, “↓” button.
- The setting value is changed if pressing “←”, “→” button.

SENSITIVITY: OFF ↔ LOW ↔ MEDIUM ↔ HIGH

- Set sensitivity of motion detection.
- Do not perform motion detection if “OFF”.

AREA SET: CH1 ~ CH16

- Set the motion detection area for each channel.

ALARM OUT: OFF ↔ ON

- Set the alarm output in the motion detection.

LIST UPDATE: OFF ↔ ON

- Set whether detection contents are recorded on the list.

BUZZER: OFF ↔ ON

- Set existence of warning sound in the motion detection.

- The background screen is changed to the relevant channel and the following screen is displayed if pressing the “ENTER” button with the blinking indication placed at the “AREA SET”:

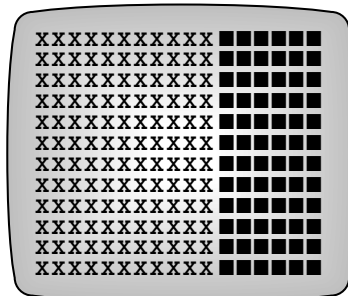

- The ■ position is a detection area.
- In setting to PIXEL unit: Move to the line to detect using the “↑”, “↓” button and press the “CAMERA SELECT” (1 ~ 16) button equivalent to the desired position. It is released if pressing the button once more.
- In selection of line: The line is selected if pressing “→” button after moving to the line to detect using the “↑”, “↓” button. In case of release, press the “←” button.
- In selection of whole of area: Press the “ENTER” button.
Press the “ENTER” button in release.
- The changed setting value is stored if pressing the “SET” button and you can return to the “MOTION SET” menu.

7. System setting

Set application of password change, buzzer and summer time.

The following screen is displayed if pressing the "ENTER" button with the blinking indication placed at the "7. SYSTEM SET" on the main menu screen:

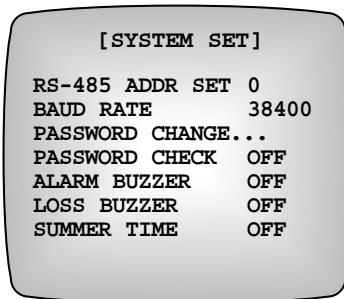

- The blinking character moves if pressing "↑", "↓" button.

- The setting value is changed if pressing "←", "→" button.

RS-485 ADDR SET: 0~255

- Set the address of this unit in using the RS-485.

BAUD RATE: 4800 ↔ 9600 ↔ 19200 ↔ 38400 ↔ 4800

- Set the baud rate of RS-232 and RS-485.

PASSWORD CHECK: ON ↔ OFF

- Set existence of the password inspection in entering into the main menu.

ALARM BUZZER: ON ↔ OFF

- Set existence of alarm sound in the occurrence of alarm.

LOSS BUZZER: ON ↔ OFF

- Set existence of alarm sound in the occurrence of loss.

SUMMER TIME: ON ↔ OFF

- Set application of summer time.
- Summer time operation delays the current time from the setting time by an hour and move up by an hour from the released time and then return to the original time.

- The following screen is displayed if pressing the "ENTER" button when the blinking position is at the "PASSWORD CHANGE...":

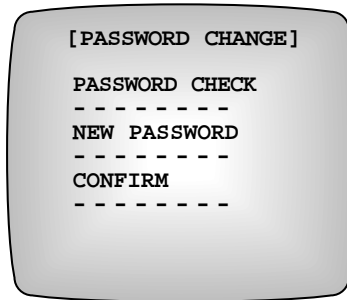

- The password in shipment from factory is "12345678".
- The first digit from the initial password check blinks.
Press the current password in order of "1" ~ "10" of the "camera select" button.
"10" is considered as "0".
- The first digit of the new password blinks if properly entering the password check as per the current password.
- Enter 8 characters of the new password to set using the "1" ~ "10" of the "camera select" button.
- Enter a new password once again from the CONFIRM.
- Message of "ERROR TRY AGAIN" is displayed on the bottom of screen if a password entry error occurs and changed the password again in the above method. Turning it by more than 3 times will completely escape from the setup menu.
- The changed setting value is stored if pressing the "SET" button and you can return to the main menu.
- * "X" is displayed on screen when entering password.

- Password check

The following screen is displayed if the "password check" turns "ON" when entering to the setup menu:

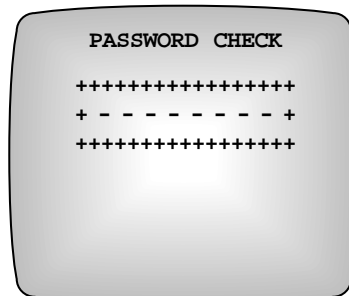

- Enter the current password in order.
- Enter into the setup menu (main menu) if the current password is proper.
- Return to the previous status if the password is wrong more than 3 times.
- * "X" is displayed on screen when entering password.

Chapter 6. Recording

1. Normal record mode

When setting the "REC TYPE" of the setup menu "1.REC OUT SET" to "NOR".

(1) Frame record

- When setting the "REC TYPE" of the setup menu "1.REC OUT SET" to FRAME.
- The image signal entered from the maximum 16 cameras is output in Frame and recorded on the VCR.
- The recorded output records the only channel that the "REC DUTY" of the "1.REC OUT SET" is set to more than 1.

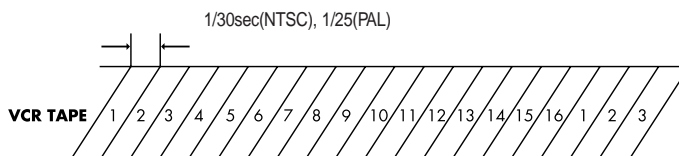

(2) Field record

- When setting the "REC TYPE" of the setup menu "1.REC OUT SET" to "FIELD".
- The image signal entered from the maximum 16 cameras is output in Field and recorded on the VCR.
- The recorded output records the only channel that the "REC DUTY" of the "1.REC OUT SET" is set to more than 1.

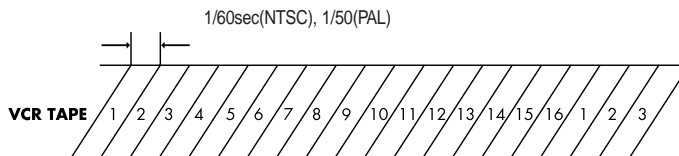

2. TIME LAPSE record mode

- When setting the "REC TYPE" of the setup menu "1.REC OUT SET" to "TLV".
- The image signal entered from the maximum 16 cameras is recorded on the VCR in response to the trigger signal of VCR.
- The recorded output records the only channel that the "REC DUTY" of the "1.REC OUT SET" is set to more than 1.
- The trigger out of VCR and the VTR terminal this unit must be connected.
- "NO TRIGGER" character is displayed on screen while operating the field record operation of the normal mode if the trigger signal is not received for 10 seconds.

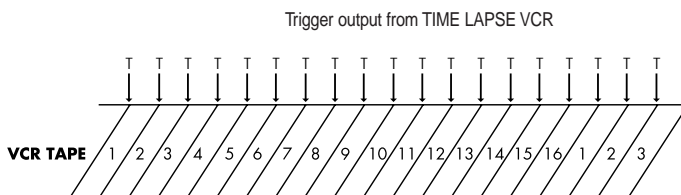

3. Weight value (REC DUTY) record

- Used to record weight value (record frequency is more than the channel whose duty is low) for the important channel.
- Perform the weight value record using the REC duty (OFF, 1~5) by channel set from the "REC DUTY" of the "1.REC OUT SET" on the main menu.
- The channel whose duty is set to "OFF" is not recorded.
- Example)
 CH1:1, CH2:2, CH3:1, CH4:3, CH5:OFF, CH6:1, CH7:1,
 CH8:1, CH9:1, CH10:2, CH11:3, CH12:1, CH13:OFF, CH14:1,

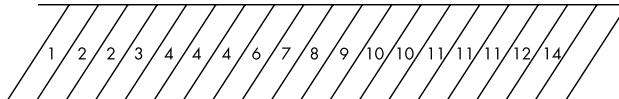

4. ALARM weight value record

- Record in the weight value only for the channels that alarm/motion occurs.
- Record by inserting the channel that alarm/motion occurs between channels.
- The duty of channels operates as "1" when recording the alarm weight value except that the REC duty is set to "OFF" (channel whose duty is "OFF" is skipped).
- Perform the alarm/motion weight value record even when alarm/motion occurs in the channels whose REC duty is set to "OFF".
- Example)
 REC DUTY
 CH1:1, CH2:2, CH3:1, CH4:3, CH5:OFF, CH6:1, CH7:1,
 CH8:1, CH9:1, CH10:2, CH11:3, CH12:1, CH13:OFF, CH14:1,
 Alarm occurring channel: CH1, CH9
 Motion occurring channel: CH3, CH9

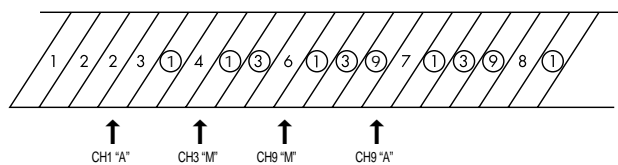

5. Reservation record

- Specific channel is used to record for a specific time.
 - Use by setting the start and time of channel setting and reservation record in the "RESERVATION" of the "1.REC OUT SET" on the setup menu.
 - The channel whose duty is set to "OFF" is not recorded.
- * Perform the alarm weight value record for the channel set to the reservation record if the alarm occurs for the period of reservation record.

Chapter 7. Occurrence and handling of alarm, loss, motion

1. Alarm occurrence conditions

The following events occur if alarm occurs since the sensor is connected to the alarm input terminal on the backside:

- 1) Warning sounds (if buzzer turns "ON").
 - 2) Alarm information (date and time when alarm occurs) is recorded on the alarm list.
 - 3) "RESET" LED blinks.
 - 4) The alarm output (HOT, COLD) signal is active for the alarm hold time.
 - 5) The record times of the channel that alarm occurs increase.
 - 6) Screen is converted to the channel that alarm occurs.
 - 7) Display character of "ALARM" or "A" appears (if the alarm information turns "ON").
 - 8) Alarm continues for the alarm hold time that is set in the program mode.
- * Alarm holds time: Time performing alarm operation after recognizing alarm.

2. Alarm release

The alarm status is released if pressing the "RESET" button when alarm occurs or the alarm holds time setting passes.

3. Screen conversion

- 1) Single alarm: The occurrence channel appears on monitor in the form of full screen.
- 2) Multiple alarm: Display the occurrence channel as the division screen depending on the occurrence numbers.
 Example) When alarm occurs at the same time in CH1, CH10, CH14 Display CH1, CH10, CH14 on the 4-division screen.

4. Alarm record

Perform the alarm weight value record in the chapter 6.

5. Alarm signal standard

You can view record output when alarm occurs during record.

For example, if record status have the following conditions:

- Currently perform record in the TLV mode on the time lapse VCR.
- Set the "REC TYPE" to "NOR" in the "5. ALARM SET" of the "program mode".

The record output until release after the alarm occurs is as follows:

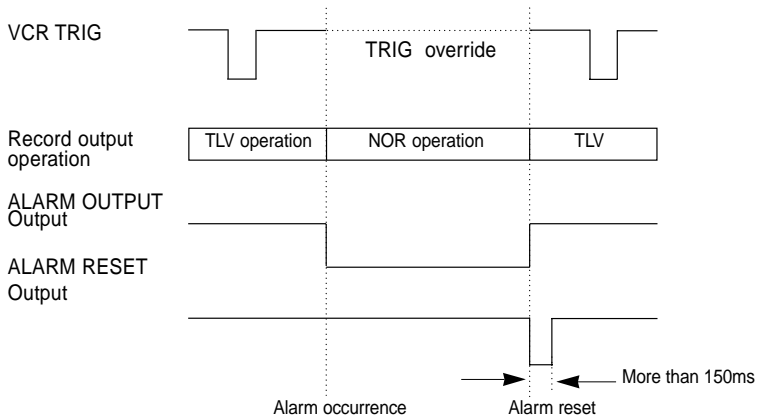

6. Alarm/Loss list reference

If pressing the "LIST" button on the front, alarm, channel loss and motion detection information recently occurred is output up to 100EA (10EA x 10 page) on screen in the occurrence as follows:

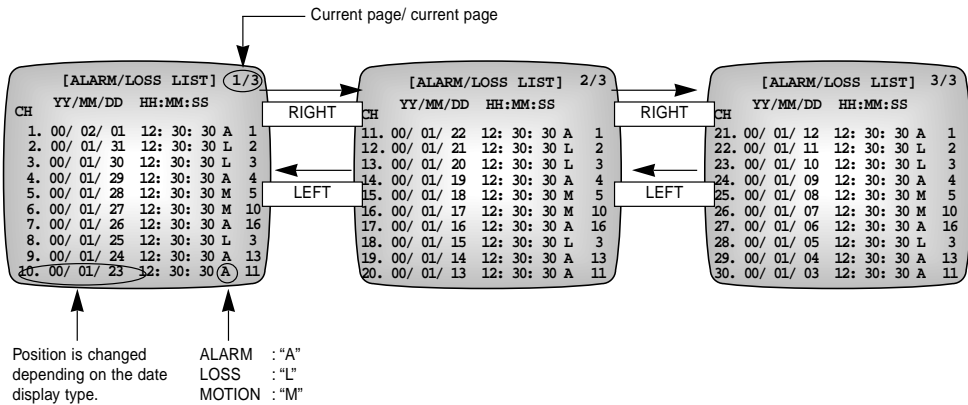

- Page moves if pressing "←", "→" button.
- Update is performed if loss occurs and motion is detected in the status that list is displayed.
- The list screen disappear and alarm operation is performed in the status that list is displayed.
- The oldest information, namely the last page is erased page by page if pressing the "RESET/ERASE" button.

7. Operation in video loss

The following operation is performed if the failure occurs in signal due to poor cable and cutting, etc for the channel that is set to "ON" in the "LOSS DETECT" of the "2.MON OUT SET" in the main menu:

- 1) Warning tone sounds (if buzzer turns "ON").
- 2) Loss information (date and time when loss occurs) is recorded on the alarm/loss list.
- 3) The "RESET" LED blinks.
- 4) Display loss information on screen using character (if the loss information turns "ON").

8. Operation in motion detection

The following operation is performed if the motion is detected in the channel set to "6.MOTION SET" in the main menu:

- 1) Warning tone sounds (if buzzer turns "ON").
- 2) Information (date and time when motion detection occurs) is recorded on the alarm/loss list.
- 3) The "RESET" LED blinks.
- 4) Display motion detection information on screen using character (if the "LIST UPDATE" of the "MOTION SET" is set to "ON").
- 5) Alarm output (HOT, COLD) signal becomes active.
(If the "ALARM OUT" setting of the "6.MOTION SET" is set to "ON")

Appendix A Specifications

1) Image input

Camera: 16 input (BNC Type, Loop Through)

1.0V_{p-p}, 75 Ω automatic termination, CVBS

VCR : 2 input (VCR Playback input)

VBS entry (BNC Type), 1.0V_{p-p}, 75Ω terminations

S-VHS Y/C input – Y: 1.0V_{p-p}, 75Ω terminations

– C: 0.286V_{p-p}(NTSC), 0.3V_{p-p}(PAL) 75 Ω terminations

– SDM-160M/SDM-160MP: Not used.

2) Image output

Monitor: 3 output

SPOT output (BNC Type), 1.0V_{p-p}, 75Ω termination

Main monitor output (BNC Type), 1.0V_{p-p}, 75 Ω terminations

S-VHS Y/C output – Y: 1.0V_{p-p}, 75 Ω terminations

– C: 0.286V_{p-p}(NTSC), 0.3V_{p-p}(PAL) 75Ω termination

– SDM-160M/SDM-160MP: Not used.

VCR : 2 output

VCR output (BNC Type), 1.0V_{p-p}, 75Ω terminations

S-VHS Y/C output – Y: 1.0V_{p-p}, 75Ω terminations

– C: 0.286V_{p-p}(NTSC), 0.3V_{p-p}(PAL) 75Ω terminations

– SDM-160M/SDM-160MP: Not used.

3) Alarm function

16 input: Outside alarm input, programmable N.O or N.C in menu

2 output: Alarm Output output, relay marked active

Alarm Reset output, OPEN COLLECTOR, TTL "L" LEVEL

Alarm hold time: 0 ~ 30 minute 59 seconds (in second)

4) AUTO SWITCHER

Auto switcher time: Selectable of 0 ~ 30 seconds

5) Multiple output screen: Full, 2,4,7,9,10,13,16, Zoom, PIP

6) Cathodized bit numbers: 8 BIT (256 pairs)

7) Sampling frequency: 4*FSC

8) Horizontal resolution: More than 400TV Lines

9) Memory Back UP: 5 years

10) Operation temperature: 0°C ~ 40°C

11) Rated voltage: AC 100 ~ 240V, 50/60Hz

12) Power consumption: less than 14 WATTS

13) Outside dimension: (W x H x D): 430 x 88 x 350 mm

14) Weight: Appr. 5.0 Kg (excluding packing materials)

OUTSIDE DRAWING

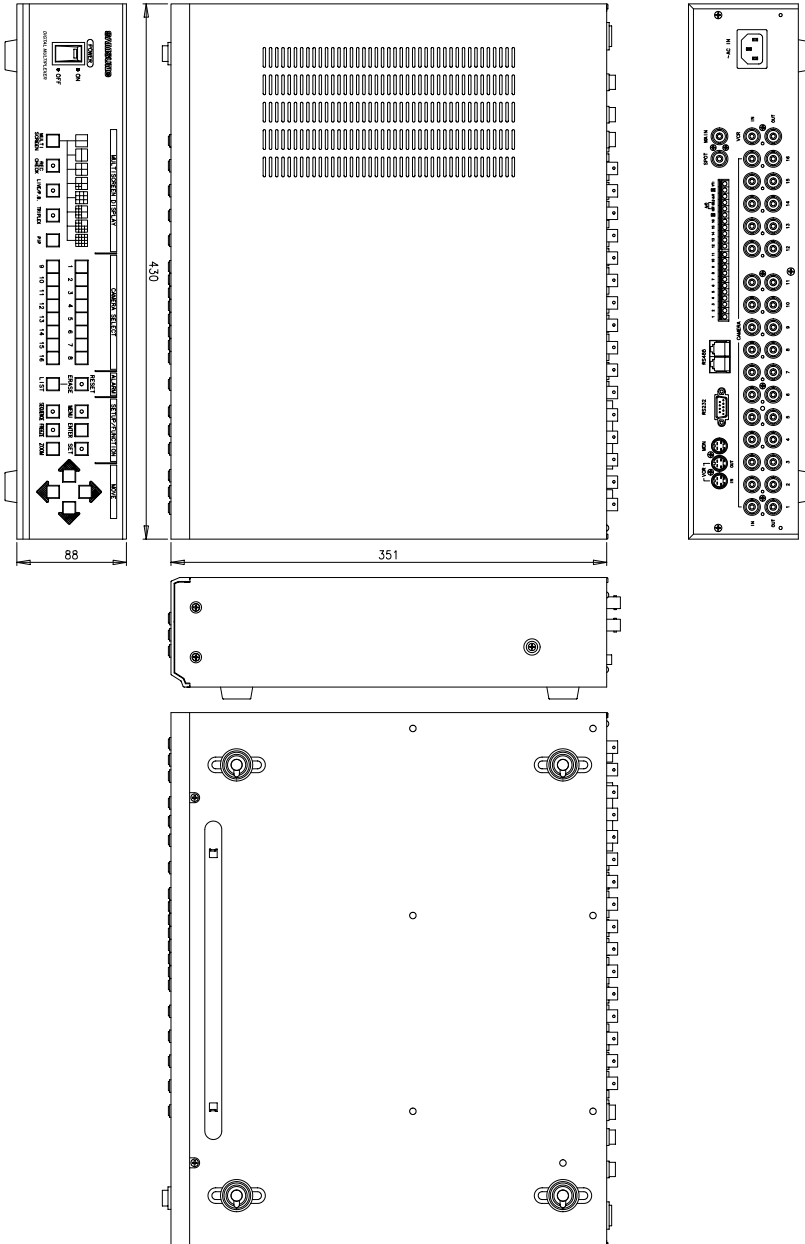

Appendix B Checking points in trouble

There may be a case not to use system properly since unexpected status occurs while using the system. In this case, such status is actually caused by a critical error in system but a simple first-aid can solve this status in the most case.

The following items must be checked when problem occurs in the use of this unit.

When power does not turn on.

- Ensure power cord is properly inserted.

When screen does not appear though the power cord is inserted.

- Ensure connection to the camera, monitor output terminal is properly performed.

When record is not done.

- Ensure the connection between the video-in terminal of VCR and the VCR OUT of this unit is properly performed.
- Ensure the record tape inserted into VCR is set to RECORD PROHIBITION.

When record is not performed in the time lapse mode.

- Ensure the connection between the video-in terminal of VCR and the VCR OUT of this unit is properly performed.
- Ensure the "REC TYPE" of the "1.REC OUT SET" among the main menu is "TLV".
- Ensure the REC trigger output terminal of the time lapse VCR is connected to the VTI terminal of this unit.

When record tape is not replayed.

- Ensure the connection between the video-out terminal of VCR and the VCR IN of this unit is properly performed.
- Ensure the connection between the video-in terminal of monitor and the MON OUT of this unit is properly performed.

When S-VHS record is not performed.

- Ensure the S-VHS IN/OUT is properly connected.
- SDM-160M/SDM-160MP:Not used.

When cannot see screen with the automatic switcher mode.

- Ensure the screen is now in the live mode.
- Ensure the time of "SEQUENCE" is set to "0" second.
The relevant channel is skipped when setting to "0" second.

NOTE

Simultaneously check even the operation status of the VCR connected when problem occurs in relation with VCR record/replay.

If problem is not solved even after checking above items and taking a step, always contact to the sale agency and request the help of expert.

